

IV Basic Physics/Dynamics of Snow Sports

Learning about the physics of sliding and motor skills development.

As a snow sports instructor, there are some basic physics with biomechanical concepts that are universal for all snow sports. These concepts revolve around how the human body utilizes the 'tool' (board/ski) to control the tool/snow interaction.

1. Skills Concept

The skills concept identifies three primary functions by which a skier/rider interacts with the snow: (*Note: Snowboarders also have the ability to twist or torque the board. This will be discussed further in the discipline specific study guide.*)

Rotary/Steering Skill: Directional guiding and steering the skis/board

Edging Skill: Tipping the tool from edge to edge about the long axis of the ski(s)/board

Pressure Control Skill: Regulating the pressure of the ski/board on the snow accomplished by vertical movements of the skier/rider

(Balancing - a function of rotary, edging and pressure control; the result of ongoing interplay of these three skills along with sensory functions of the skier/rider activating deliberate and unconscious bodily movement)

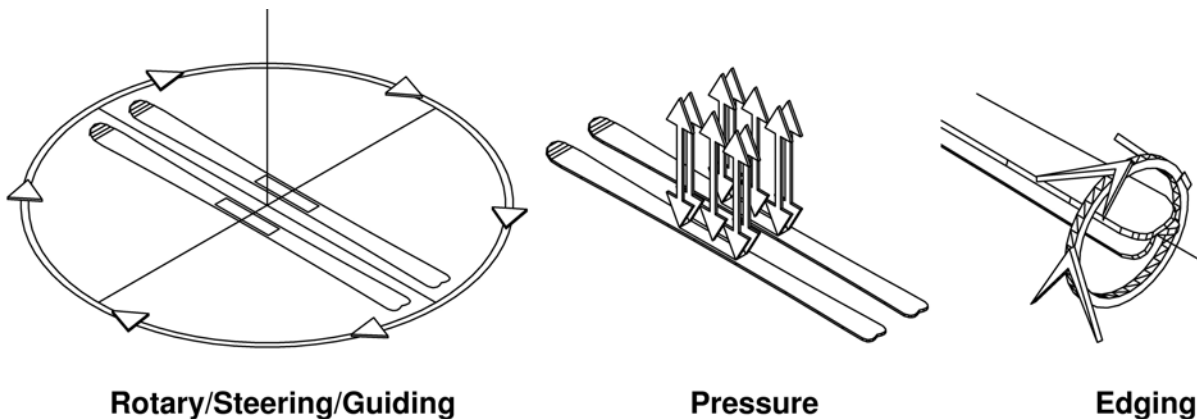

(*Note: The above diagram shows skis only for clarity.*)

Some of the most important things in snow sports cannot be taught, but they can only be learned; i.e. learning to improve balance can often be assisted by deliberately disturbing balance in a controlled environment. For the new and beginner rider/skier, improving balance along with controlling speed is a top priority. Let us elaborate:

1. Spatial awareness is an important part of 'learning to learn'. Many students will require extensive awareness practice to gain a better sense of space and time.
2. Sensing when we are in/out of balance is a given mechanism, but the speed and nature of our responses to sensing ourselves to be in/out of balance is trainable. Strength, agility, flexibility, response options are basic elements we can train students in.

3. Exercises improving balance in the spirit of the above include, but are not limited to, learning how to carry arms - our balancing poles; practicing push-over while standing, learning experientially to adjust our way of standing by contracting our core muscles and flexing all joints.

Proprioceptive Awareness x Muscular Strength = Equilibrium.

The one variable that is innate and cannot be changed is the time required to signal disequilibrium to the muscle response. THAT is a birth given reaction time that can only be optimized by increased awareness and the directed strength of the muscular response. The wiring/inner ear sensory mechanism is a given from birth.

In your discipline/s, which do you consider to be the first skill that can begin to be mastered and why? _____

Which do you consider to be the most difficult to master and why? _____

2. Basic Physics

Gravity and friction are the basic physical forces that effect you on the snow. They are your 'engine'. You spend your time 'playing' with these forces as they effect your body on your 'tool'.

Turning is what defines both skiing and riding. Gravity and friction and your body mass in motion down the inclined plane produce the forces that you manage with the three basic skills of rotary, edging and pressure control on your tool. Gravity and friction create momentum that you manipulate as you turn necessitating managing also centripetal force.

[Note: The nordics also go uphill and along the flats. The Nordic Study Guide will elaborate on that!]

You can make this as complicated or as simple as you like and you will find much in the literature discussing this as you continue your study.

However, understanding at a basic level how forces are generated as well as diminished is at least helpful. Fundamentally, whenever two forces are in the same direction, the resulting force increases; i.e. in the lower part of a turn, after the gravity line (alias falline), when gravity is pulling you down the hill, if you resist gravity by also pushing against your edge/s at that time, you increase the force on you and your 'tool' - what you feel is an increase in pressure on your board/skis. Conversely, if at that same moment, you move with the force of gravity with your body mass, you will decrease the total force and you will feel less pressure on your board/skis.

Research and continue to think in terms of forces and what you feel at other points of the turn. What is going on at the apex of a turn?

What about when you are heading across the hill on your edges? _____

What about when you are sideslipping down the hill? _____
